

# ***3-matic*<sup>STL</sup>**

Tutorial Videos: Lightweight Structures

# 3-matic<sup>STL</sup>: Design a 3D Conformal Structure



This video shows how to design a structure conformal to the surface of your model. The 3-matic<sup>STL</sup> patterning function generates 3D patterns that follow the curvature of the part.

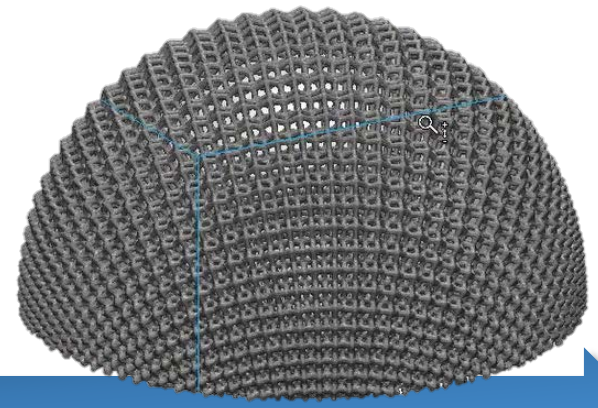
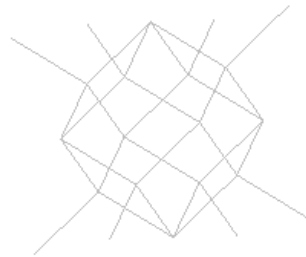
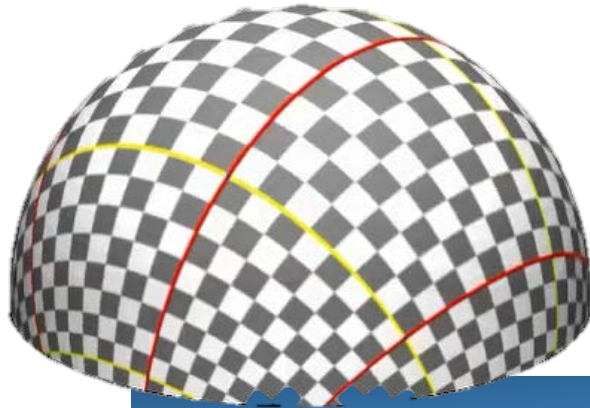

# 3-matic<sup>STL</sup>: Design a Randomized Structure



This video shows how to design a randomized structure starting from a unit structure and setting minimum and maximum randomization levels.

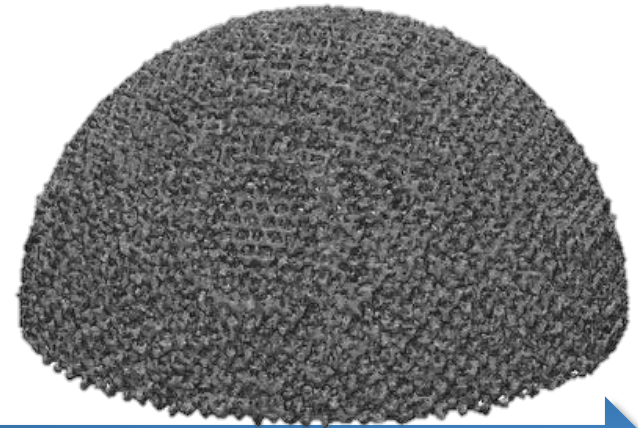
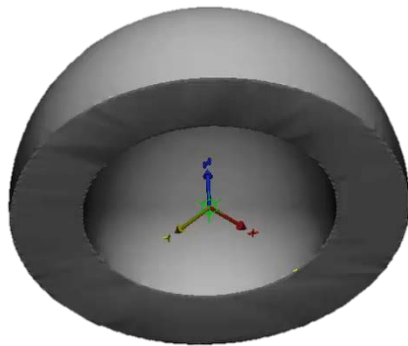

# 3-matic<sup>STL</sup>: Design a Trimmed Randomized Structure



This video shows how to design a randomized structure starting from a unit structure and trim the small edges that extend beyond the original external surface.

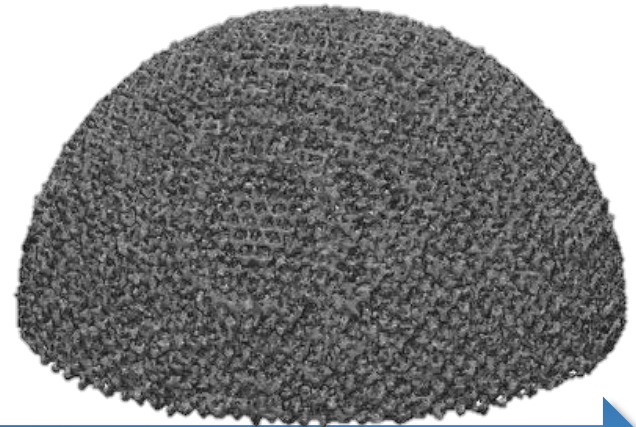
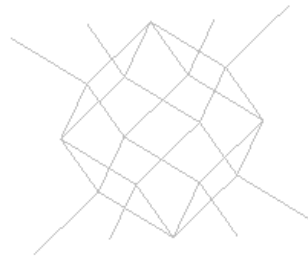
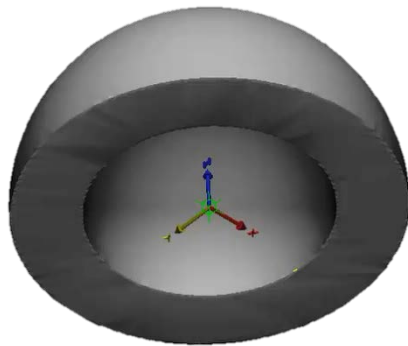

## *3-matic<sup>STL</sup>: Design a Randomized Structure with Offset*



This video shows how to design a randomized structure that fits perfectly to the original model geometry. In this example, no trimming is used.

To create this perfect fit, an offset is created from the original model geometry. Starting from a unit structure, minimum and maximum randomization levels are set, generating a randomized structure that does not extend beyond the original external surface.

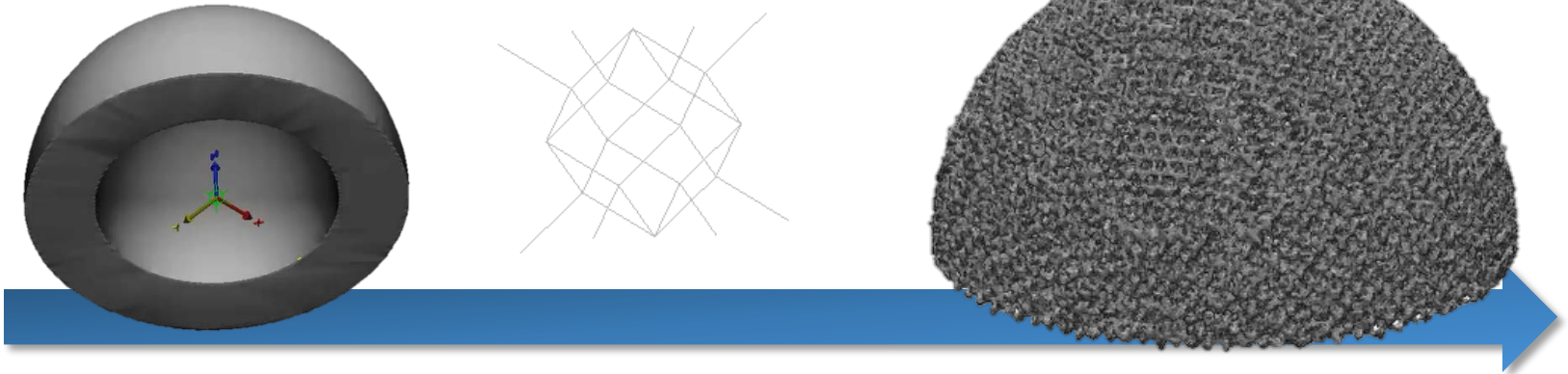

# 3-matic<sup>STL</sup>: Design a Structure Within a Steering Wheel



This video shows how to design a structure to be applied to the inside of a steering wheel while leaving the other parts of the steering wheel solid.

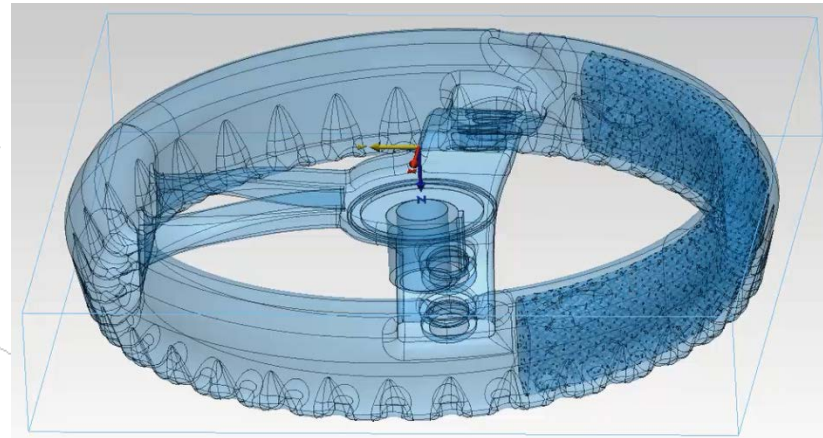
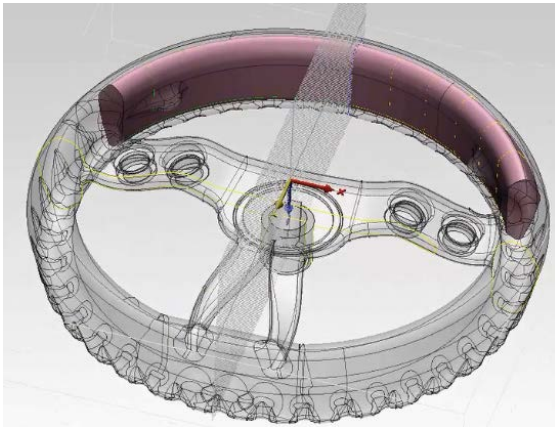

# 3-matic<sup>STL</sup>: Design Your Own Unit Cell



This video shows how to design a unit cell. This procedure can also be done in any other software and imported to 3-matic<sup>STL</sup> as Iges files, which present the structure in lines.

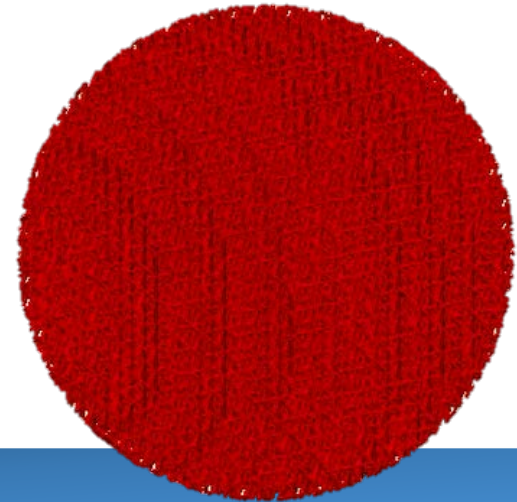
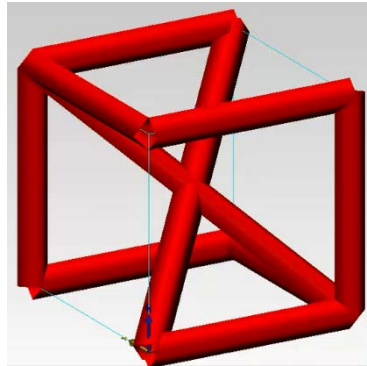

# 3-matic<sup>STL</sup>: Design a Randomized Filtered Volume Structure



This video shows how to design a volume structure. After designing your structure, lines that have only one connection point and are under a certain angle can be filtered and removed.

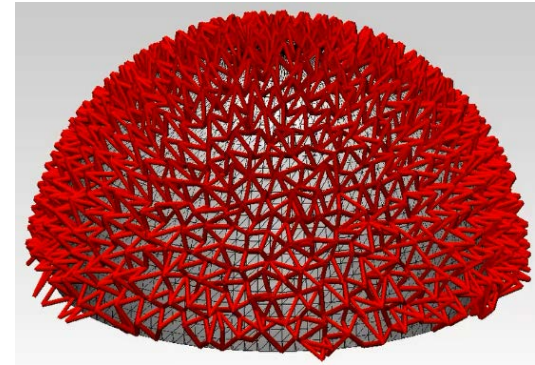
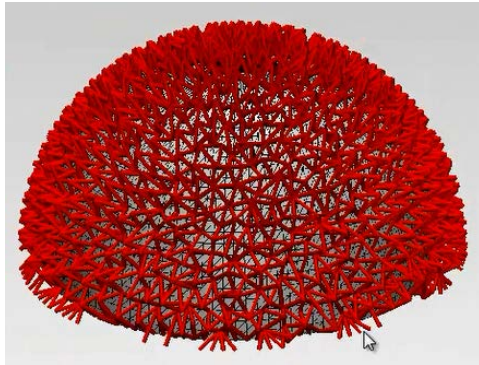



# 3-matic<sup>STL</sup>: Part 1: Design a Radial Structure Within a Filter



This video shows one of the possible ways of designing a radial structure within a filter. By creating an offset inside the filter, a connection can be made between the two radial surfaces.

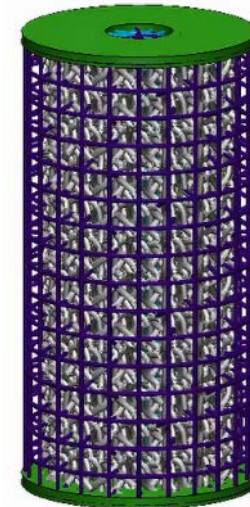
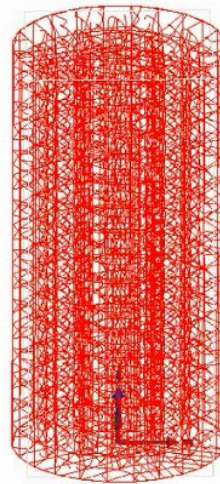
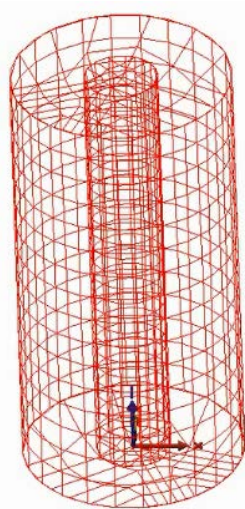

## *3-matic<sup>STL</sup>: Part 2: Wrap a Sketched Structure Onto a Filter*



This video shows how to fold a sketch onto a surface, where it is then converted to graphs and sized for placement into the filter of the previous exercise.

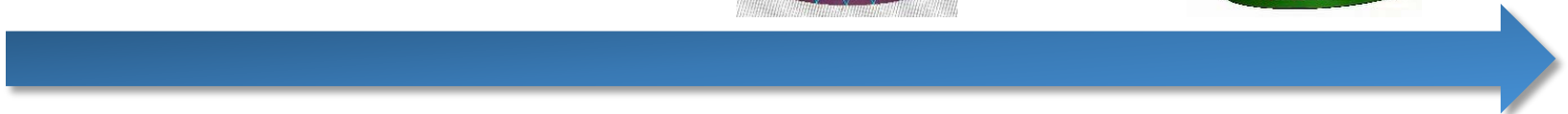
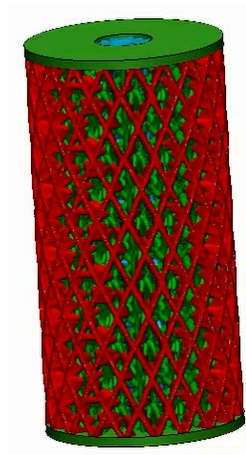
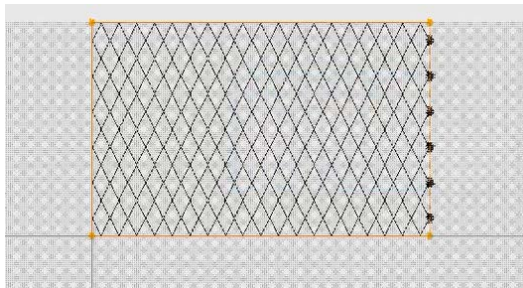

# 3-matic<sup>STL</sup>: Design a Wing with Gradient Structure



This video shows how to design a structure that has a density gradient. In this example, a wing is subdivided into 3 sections with different mesh sizes. Afterwards, a volume graph is applied.

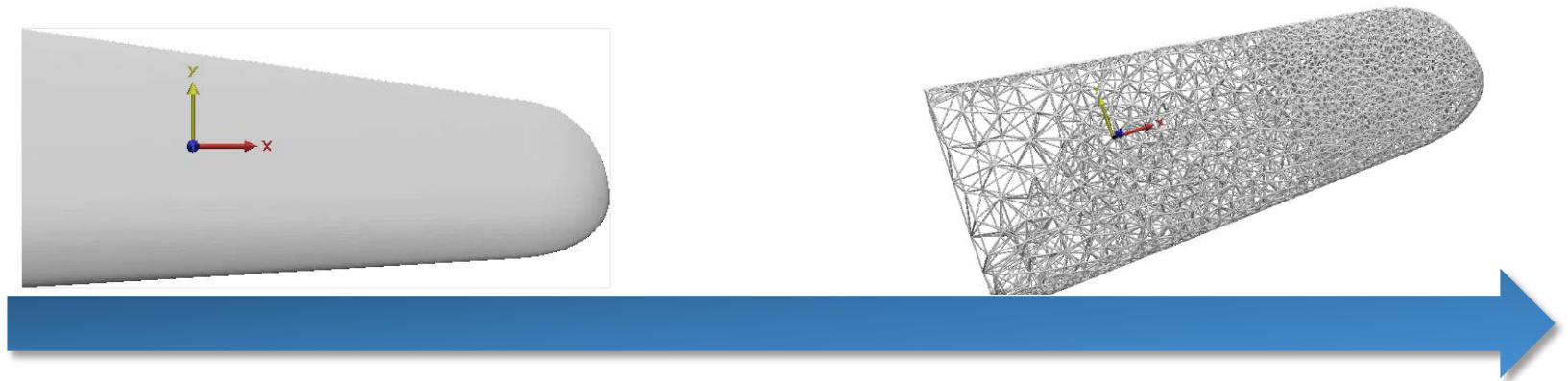

# 3-matic<sup>STL</sup>: Using the randomize seed value and macros



This video demonstrates how to use the randomize seed value and how to create and apply a macro. Starting from a randomized graph, the resulting seed value is incorporated into a macro. This macro is then easily applied to create randomized unit graphs.

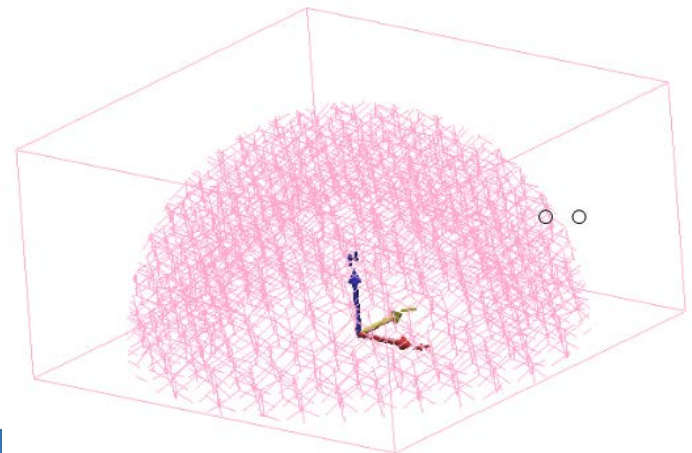
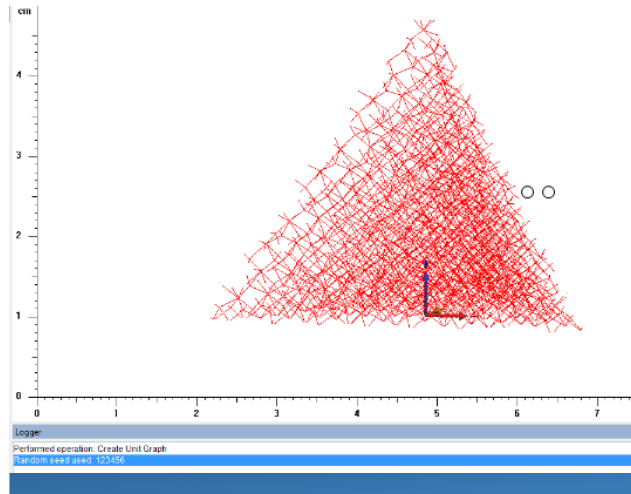

# Thank You!

Any questions? Please contact  
[software@materialise.be](mailto:software@materialise.be)