

Linea T-TYPE

LAZZATI

High-Performance Boring-Mills®

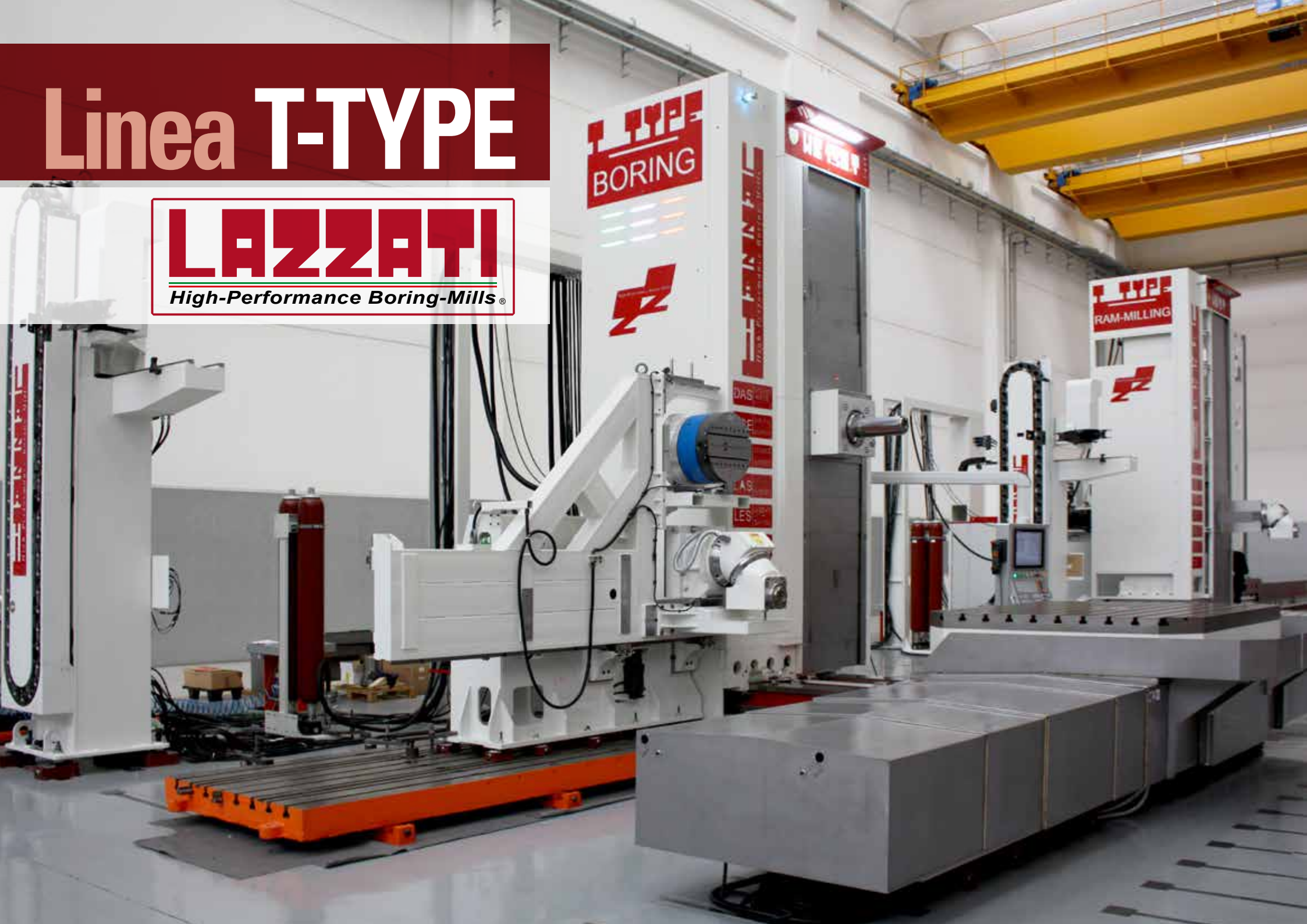

> T-Type

LAZZATI, a company specialized in the design and manufacture of heavy horizontal boring and milling machines since 1939, is pleased to introduce the **new Linea T-Type, the latest innovative series of horizontal boring mills and milling borer machines with moving T column**, with two separate and independent beds, rigidly linked by the foundation. The machines of the Linea T-Type are designed to reach maximum performances and thanks to their absolute rigidity and strength are capable of performing the most varied milling, boring, drilling and threading works.

LAZZATI beschäftigt sich seit 1939 mit der Entwicklung sowie Herstellung von Bohrwerken und Horizontalfräsmaschinen großer Abmessungen. Hiermit wird die **neue Baureihe T-Type vorgestellt als neueste Horizontalfräsmaschine und Bohrwerk als Fahrständerversion in T-Bauform**, mit zwei unabhängigen Betten, die steif mit dem Fundament verbunden sind. Die Maschinen der Baureihe T-Type sind auf höchste Leistungen ausgelegt. Aufgrund ihrer Robustheit und Steifigkeit können sie vielseitiges Fräsen, Ausspindeln, Bohren und Gewindeschneiden durchführen.

LAZZATI, azienda specializzata dal 1939 nella progettazione e costruzione di alesatrici e fresatrici orizzontali di grandi dimensioni, è lieta di presentare la **nuova Linea T-Type, l'ultima innovativa serie di alesatrici fresatrici orizzontali a montante mobile con morfologia a T**, con due bancali indipendenti uniti rigidamente alla fondazione. Le macchine della Linea T-Type sono progettate per permettere le massime prestazioni e, grazie alla loro assoluta rigidità e potenza, sono in grado di eseguire le più svariate lavorazioni di fresatura, alesatura, foratura e filettatura.



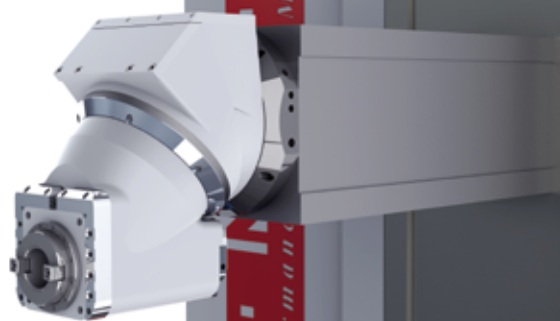

Linea T-Type
RAM-MILLING



Linea T-Type
BORING

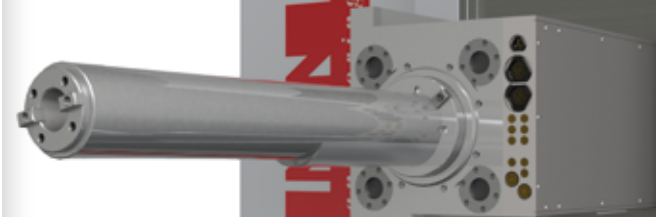

Linea T-Type
RAM-BORING



> RAM-MILLING

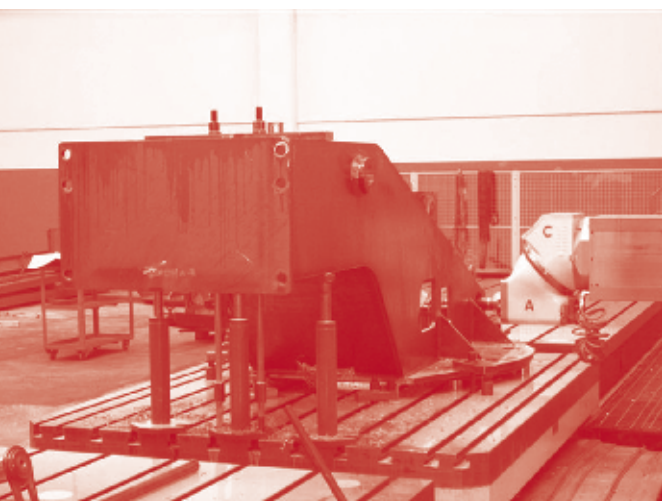

RAM-MILLING:

Head with Milling Borer RAM movement, travel 1600mm., equipped with universal controlled head.

Kopf mit Fräs- und Ausbohr-Stößelbewegung (RAM), Verfahrweg 1600mm., ausgestattet mit ansteuerbarem Universalkopf.

Testa con movimento RAM di fresalesatura con corsa 1600mm., equipaggiata con testa universale controllata.



> FAST HEAVY VERSATILE MACHINES

HB 2T >



> MILLING



RAM-MILLING:

Head with Milling Borer fix RAM. = 500mm., equipped with universal controlled head.

Kopf mit fix RAM. = 500mm., ausgestattet mit ansteuerbarem Universalkopf.

Testa con RAM fisso di fresalesatura = 500mm., equipaggiata con testa universale controllata.

> FAST HEAVY STRONG MACHINES

HB 2TF >



> BORING

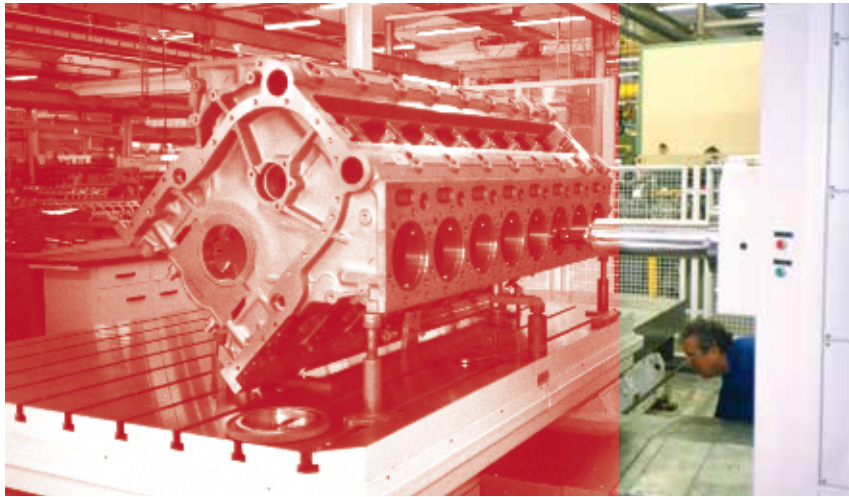

> **FAST**
HEAVY
PRECISION
MACHINES

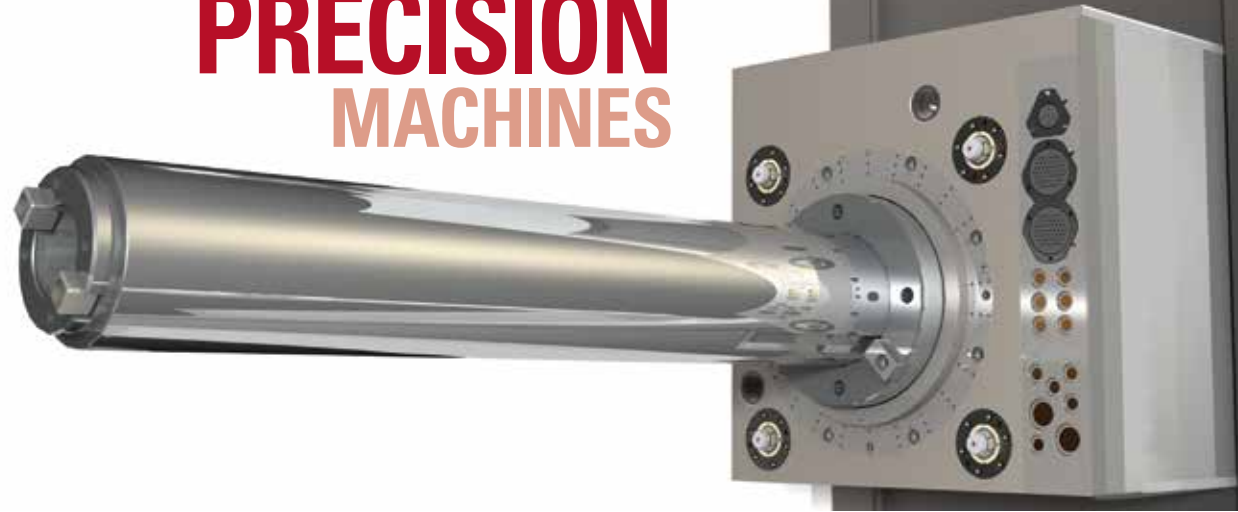

BORING:

Head with boring spindle movement $\varnothing 130 \div 180$ mm., travels $800 \div 1.300$ mm., equipped with interface for accessory heads.

Kopf mit Ausbohrspindelbewegung mit $\varnothing 130 \div 180$ mm., Verfahrwege $800 \div 1300$ mm., ausgestattet mit Schnittstelle für Zusatzköpfe.

Testa con movimento di mandrino di alesatura con $\varnothing 130 \div 180$ mm., corse $800 \div 1.300$ mm., equipaggiata con interfaccia per teste accessorie.



HB 130T >



BORING

HB 130T

RAM-MILLING

- DAS
- DCE
- DPS
- LAS
- LES
- RD
- CS

RAM-MILLING

RAM-MILLING

> HB 150T



HB 160T >



> RAM-BORING

> FAST HEAVY POWER MACHINES

RAM-BORING:

Head with Milling Borer RAM movement, travels 700 ÷ 1000mm. and boring spindle movement $\varnothing 130 \div 180$ mm., travel 1.000mm., equipped with interface for accessory heads.

Kopf mit Fräs- und Ausbohr-Stößelbewegung (RAM) mit Verfahrswege 700÷1000mm. und Ausbohrspindelbewegung mit $\varnothing 130 \div 180$ mm., Verfahrsweg 1000mm., ausgestattet mit Schnittstelle für Zusatzköpfe.

Testa con movimento RAM di fresatura con corse 700÷1.000mm. e movimento di mandrino di alesatura con $\varnothing 130 \div 180$ mm., corsa 1.000mm., equipaggiata con interfaccia per teste accessorie.

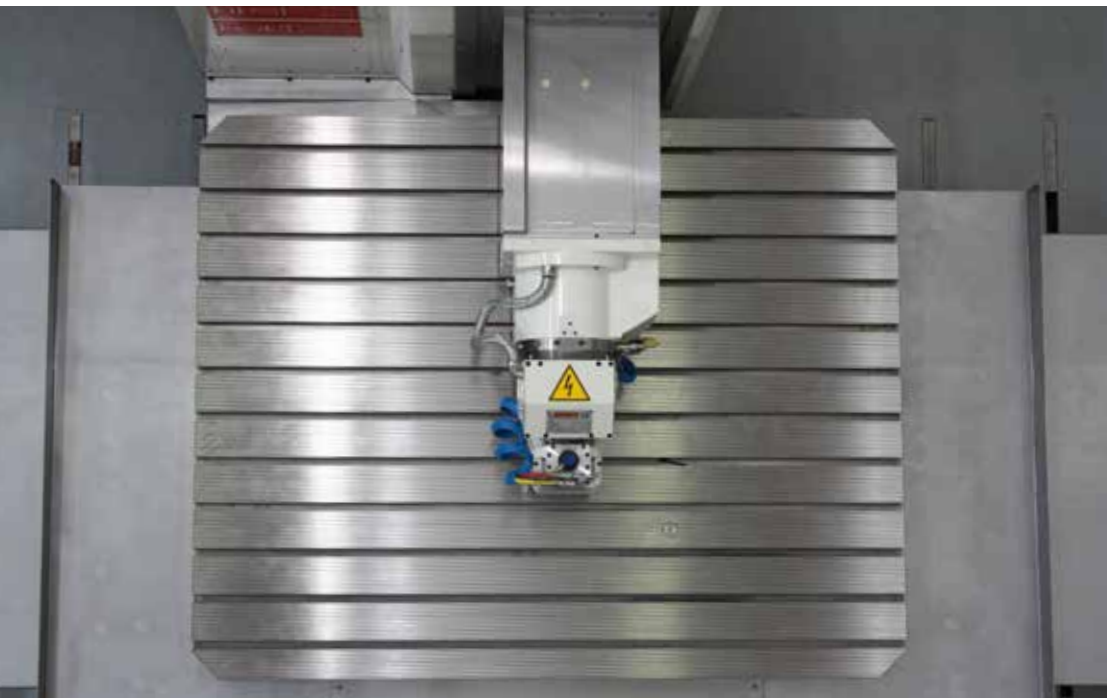

> HB 160MT



RAM-BORING

HR 160 MT

HFNPF
High-Performance Boring-Mills

- DCE
- TCS
- LRD
- LES
- DPS
- DSR

> Mobile head Beweglicher support Testa mobile

The mobile head is a sturdy construction of fine-grain perlitic stressrelieved cast-iron. It houses the controls for spindle rotation, the stepless variable motor and the automatic change over gearbox. The spindle is accurately balanced and runs in high-precision preloaded angular-contact ball-bearings. A thermostabilization circuit controls the spindle temperature in order to avoid excessive elongation of the spindle.

The system can be provided with coolant delivery through the inside of the spindle. Tool clamping and unclamping is carried by Berg collets. A double hydraulic and electronic compensation system on the mobile head allows the unit to remain within the prescribed tolerances during horizontal travel and also to compensate any difference in weight due to automatic loading of the special accessories.

Die robuste Konstruktion aus spannungsfreiem Perlit-Guss enthält alle Antriebe zur Spindeldrehung, den Motor für die stufenlose Drehzahlregelung und das Schaltgetriebe mit automatischen Schaltstufenwechsel. Die sorgfältig ausgewuchtete Spindel läuft in vorgespannten Schrägkugellagern hoher Genauigkeit.

Ein thermisch stabilisierender Kühlkreislauf sorgt für eine konstante Spindeltemperatur um eine übermäßige Wärmeausdehnung der Spindel zu vermeiden.

Alle Maschinen sind standardmäßig mit Kühlmittelzufuhr durch das Spindelzentrum ausgestattet. Zum Spannen der Werkzeuge ist ein Berg-Spannsystem verbaut. Die Tragbalkenmaschinen verfügen über eine hydraulisch-elektronische Kompensationsmöglichkeit um den Durchhang auszugleichen. Zusätzlich wird das Neigen der Tragbalkenkonsole und des Maschinenständers hydraulisch kompensiert.

Robusta fusione in ghisa perlitica stabilizzata, la testa mobile incorpora tutti i comandi per la rotazione del mandrino, il motore a variazione continua ed il riduttore per il cambio automatico della gamma. Il mandrino, accuratamente bilanciato, è supportato da cuscinetti a sfera obliqui precaricati, di altissima precisione. Un circuito termostabilizzatore provvede a controllare la temperatura del mandrino onde impedire allungamenti eccessivi dello stesso. È possibile l'adduzione di liquido refrigerante all'interno del mandrino. Il bloccaggio e lo sbloccaggio automatico dell'utensile sono ottenuti con pinze Berg. Un doppio dispositivo compensatore, idraulico ed elettronico, permette di mantenere la testa mobile nelle tolleranze prescritte durante il suo movimento orizzontale, recuperando inoltre le differenze di peso dovute al carico automatico delle attrezzature.

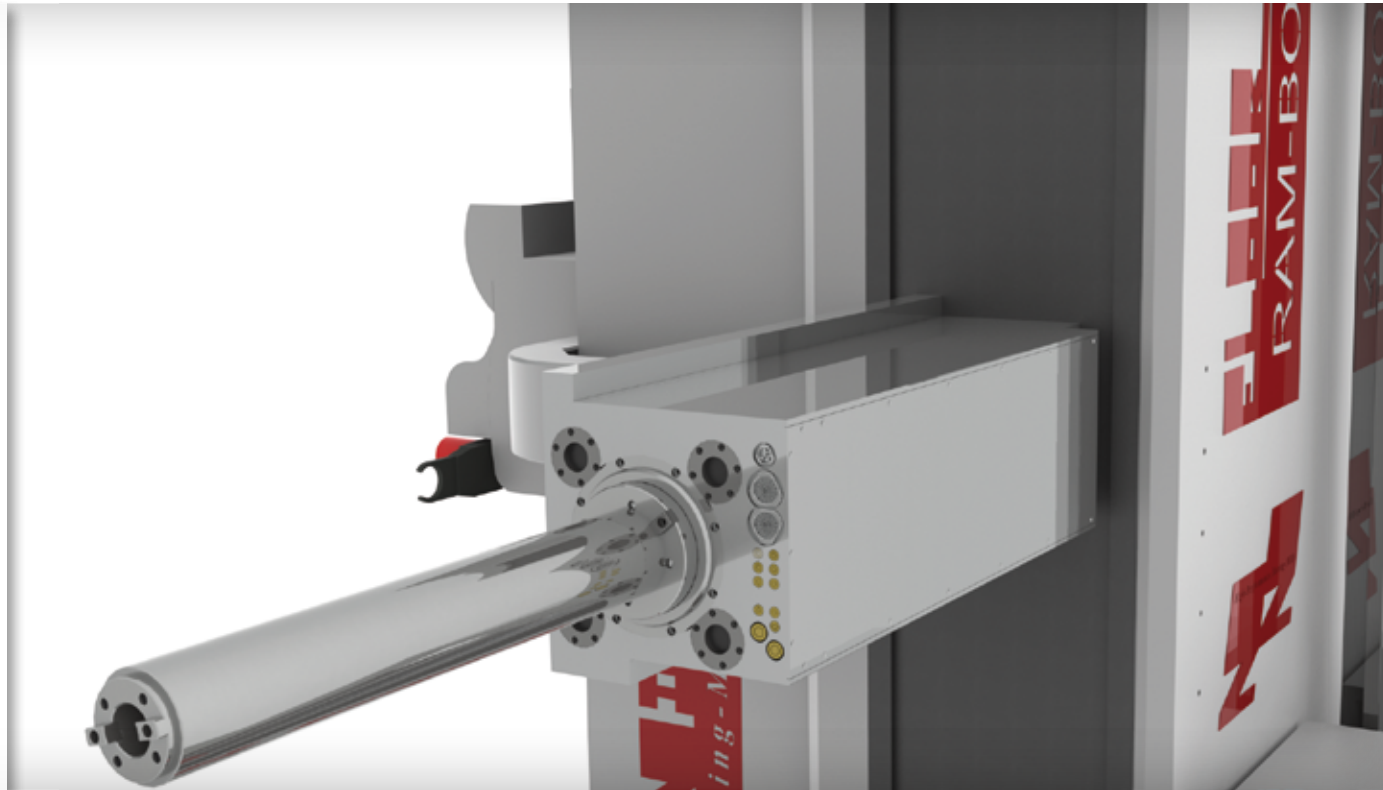



DCS Dynamic Compensation System >

Dynamic compensation system which lets the head to be always perpendicular to the column slideways 0,015 / 1.600mm.
 System zur dynamischen Kompensierung des Absenkens des Rams (Stößel) bei einer Genauigkeit von 0,015 / 1.600mm.
 Sistema di compensazione dinamica della caduta del Ram con precisione di 0,015 su 1.600mm.

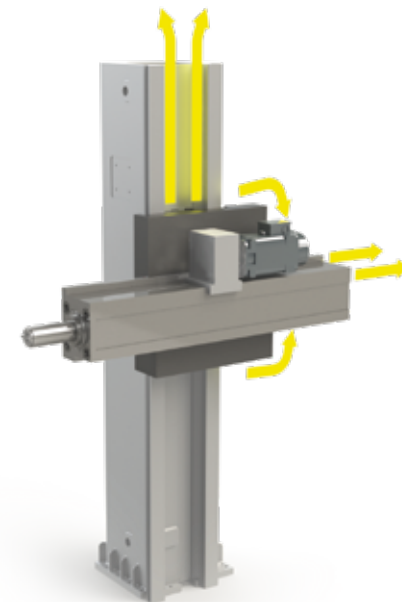
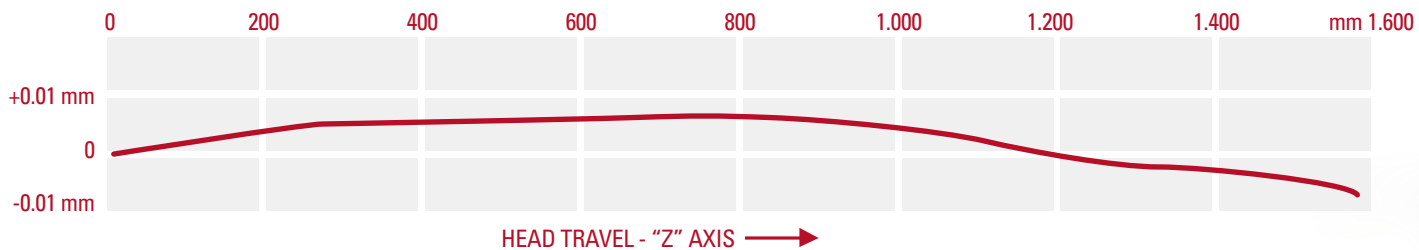

**Ergonomic Design:**

- Optimal visibility
- Facilitated access and positioning of the pieces
- Total exploitation of the working area
- Max comfort for the operator

Modularity:

- Table X travels up to X=7.000mm.
- Possibility to have different table configuration and different table loads
- Different possibility of positioning according to the customer's request

Rigidity:

- Very rigid design of the two beds
- Compact design
- Lowest distance from the floor
- Spindle Headstock very close to the table center

Ergonomische Konstruktion:

- Ausgezeichnete Einsicht in die Maschine
- Erleichterter Zutritt zur Maschine und einfaches Aufsetzen der Werkstücke
- Optimale Ausnutzung des Arbeitsbereiches
- Gute Bedienerfreundlichkeit

Modularbauweise:

- Verfahrweg in X-Achse bis 7.000 mm
- Verfügbarkeit von verschiedenen Tischversionen und Tischbelastungen
- Ausgezeichnete Gestaltung bei der Maschinenaufstellung

Steifigkeit:

- Konstruktion ausgelegt für höchste Steifigkeit der beiden Maschinenbetten
- Kompakte Konstruktion
- Geringe Höhe über dem Hallenboden
- Geringster Spindelabstand zur Tischmitte

Design Ergonomico:

- Visibilità ottimale
- Accesso e piazzamento dei pezzi facilitato
- Massimo sfruttamento dell'area di lavoro
- Massimo comfort per l'operatore

Modularità:

- Corsa Asse X fino a X=7.000mm.
- Possibilità di avere differenti configurazioni di tavole e differenti portate
- Massima personalizzazione del piazzamento

Rigidità:

- Design rigidissimo dei due bancali
- Design compatto
- Minima distanza dal pavimento
- Mandrino vicinissimo al centro tavola

> **Advantages**



> LHS-T

LAZZATI Hydrostatic System for T-TYPE

The advantages of this LHS LAZZATI Hydrostatic System for T-Type:

- no friction and so elimination of stick-slip;
- high stiffness with reduction of vibration;
- no slide wear thus keeping the precision for long time;
- highest response fidelity to the control pulses and thus positioning precision.

Die Vorteile LAZZATI Hydrostatic System T-Type im folgendem:

- Reibungsfreies verfahren der Maschinenachsen ohne Stick-Slip- Effekt;
- große Steifigkeit und Dämpfung der Schwingungen;
- Kein Verschleiß der Führungsbahnen und damit Beibehaltung der Maschinengenauigkeit;
- Hervorragendes Ansprechverhalten der Maschinenachsen sehr hoher Positioniergenauigkeit.

I vantaggi dell'utilizzo del sistema LHS LAZZATI Hydrostatic System per T-Type sono:

- assenza di attrito con conseguente eliminazione dello stick-slip;
- grande rigidità con attenuazione delle vibrazioni;
- nessuna usura delle guide, con conseguente mantenimento delle precisioni nei posizionamenti;
- massima fedeltà di risposta agli impulsi di comando, con conseguente precisione nei posizionamenti.

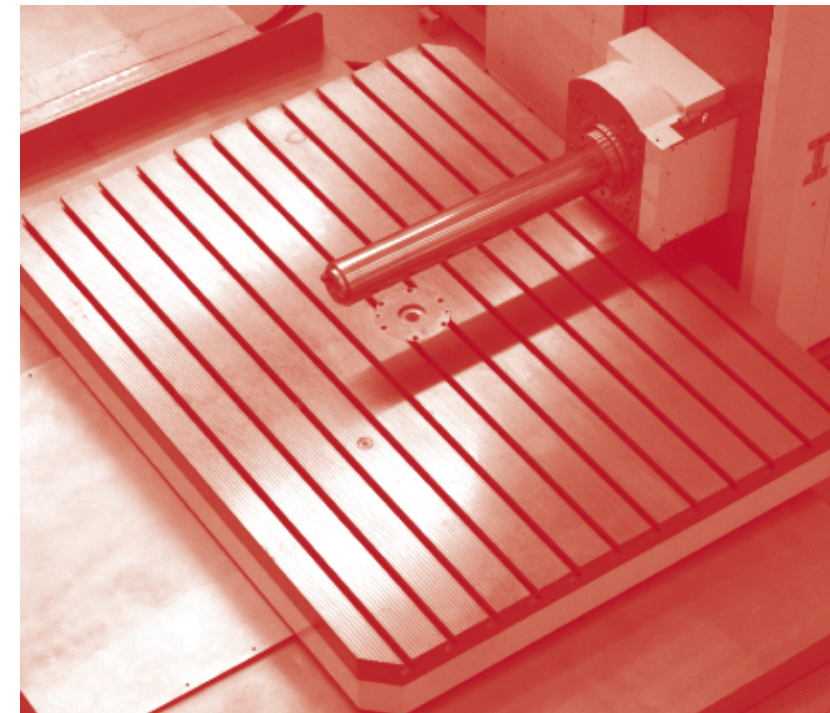

Technology >

LHI 4.0

LAZZATI HUMAN INTERFACE 4.0

>LHI LAZZATI Human Interface 4.0

New-generation man-machine interface tool Mechatronic Technologies 4.0.

Mensch-Maschine-Schnittstellentool Mechatronische Technologien 4.0.

Strumento di interfaccia uomo-macchina Tecnologie Meccatroniche 4.0.

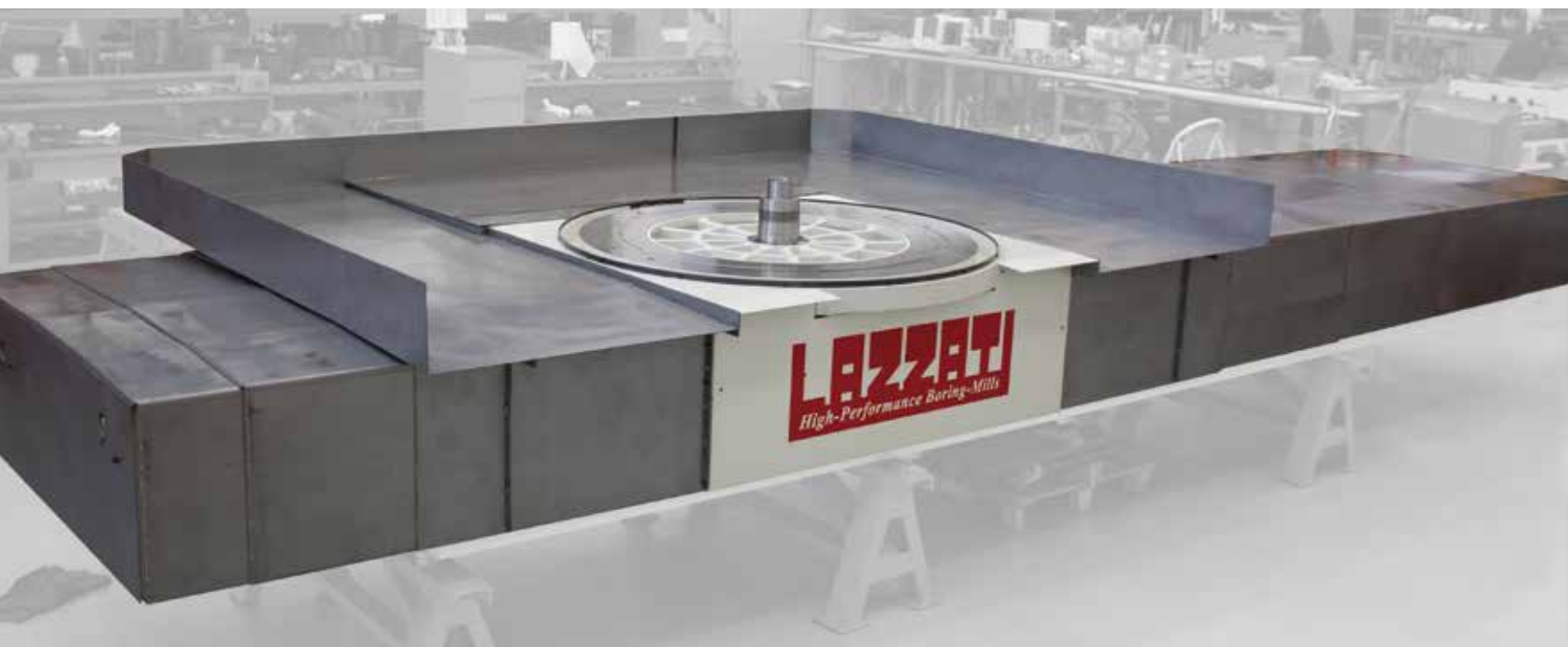

>DPS Double Pinion System

Double pinion cinematic system, with automatic backlash recovery on B axis projected and implemented by LAZZATI.

Von LAZZATI konstruiertes und weiterentwickeltes Antriebssystem über Doppelritzel mit Spielausgleich an den linearen und rotativen Achsen.

Sistema di cinematica a doppio pignone con recupero del gioco per assi lineari e rotativi progettato e sviluppato da LAZZATI.

>DAS Dynamic Axis Setting

Dynamic setting system of axes' rotation.

Dynamisches Steuerungssystem der Rotationsachsen bei unterschiedlichen Belastungen.

Sistema di gestione dinamico della taratura degli assi rotanti.

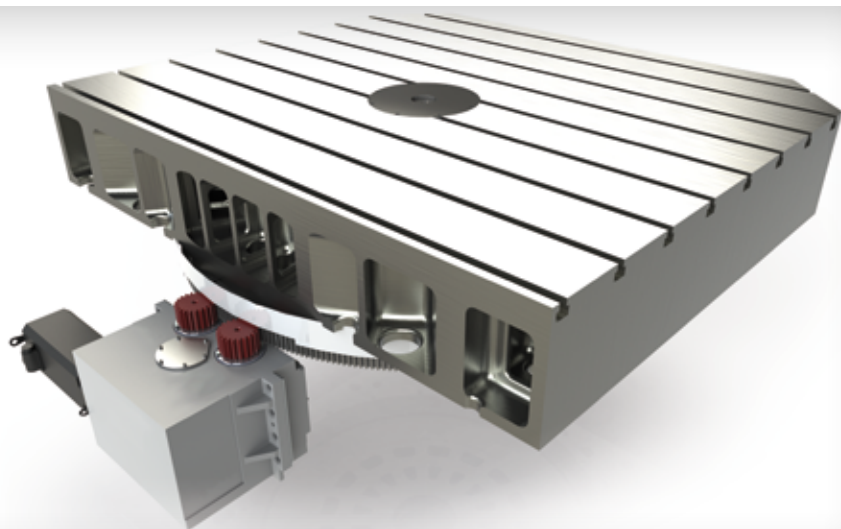

>ELC Eccentric Load Compensation

Compensation system projected and implemented by LAZZATI to maintain the maximum precision also with eccentric Load on B Axis.

Diese von LAZZATI entwickelte System, kompensiert außermittige Drehtischbelastungen und erhöht die Tischschlaggenauigkeit um ein vielfaches.

Sistema di compensazione progettato e sviluppato da LAZZATI per mantenere la massima precisione anche a carichi eccentrici sull'Asse B.

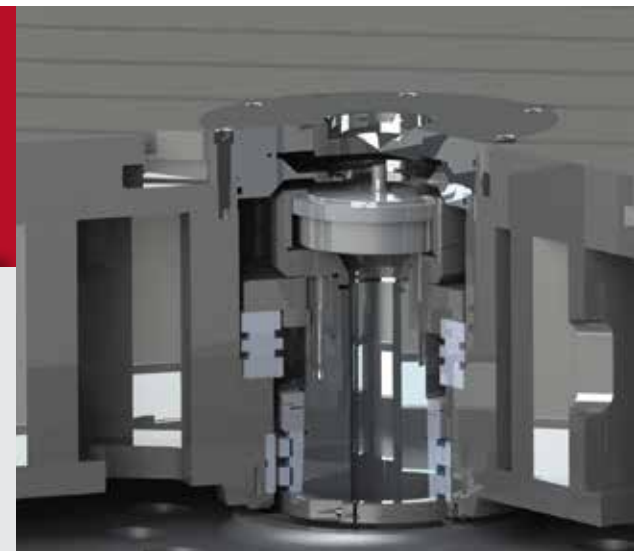

> LES LAZZATI Energy Saving

ENERGY SAVING Up to 25% of energy saving due to the special project LAZZATI of the electrical plant. **OIL SAVING AND PROTECTION** Thanks to the hydrostatic system only a short and defined lubrication's oil quantity is used, which is all recovered and re used. In fact, the system is a completely closed one, with no leakage. **COOLANT SAVING AND PROTECTION** All coolant is taken by the chip conveyor and by a tank in the foundation and it's all filtered, cleaned and brought into the main coolant tank. **SPACE SAVING** LAZZATI design saves a great space in the plant. **LOW NOISE LEVEL** Under the noise level of 80db, as prescribed by the applicable EC legislation.

ENERGIEERSPARNIS Bis 25% Energieersparnis bei den elektrischen Anlagen. **ERSPARNIS VON ÖEL SOWIE SICHERHEIT IM CHMIERSYSTEM** Verwendung einer kleinen genau bestimmten Ölmenge, die aufgefangen und wieder verwendet wird. Das gesamte Schmiersystem wurde von LAZZATI entwickelt und erstellt, wobei es vollständig geschlossen und verlustfrei ist. **ERSPARNIS VON KUEHLSTOFF SOWIE SICHERHEIT IN DER KUEHLANLAGE** Der Kühlstoff wird in dem Späneförderer und der Wanne aufgefangen, gefiltert und gereinigt und in den Hauptkühlmitteltank zurückgeführt. **PLATZERSPARNIS** Durch gezielte Projektplanung durch Lazzati wird der vorhandene Platz optimal genutzt unter Berücksichtigung aller ergonomischen Grundsätze. **NIEDRIGER GERÄUSCHPEGEL** Geringer als 80 dB in Übereinstimmung mit den anwendbaren EG-Vorschriften.

RISPARMIO DI ENERGIA Fino al 25% di risparmio energetico grazie al progetto LAZZATI dell'impianto elettrico. **RISPARMIO DI OLIO E SICUREZZA DELL'IMPIANTO LUBRIFICANTE** Impiego di una piccola e definita quantità di olio lubrificante, che viene recuperato e riutilizzato. L'intero sistema dell'impianto lubrificante è stato progettato e studiato da LAZZATI per essere completamente chiuso e non avere dispersioni. **RISPARMIO DI LIQUIDO REFRIGERANTE E SICUREZZA DELL'IMPIANTO REFRIGERANTE** Il liquido refrigerante, una volta recuperato dal convogliatore di trucioli e dalla vasca, viene filtrato e pulito e, successivamente, trasportato nella vasca refrigerante principale. **RISPARMIO DI SPAZIO** Il progetto LAZZATI permette di ottenere un grande risparmio di spazio ed il rispetto dei principi di ergonomia. **BASSO LIVELLO DI RUMORE** Inferiore a 80db, come prescritto dalla norme CE applicabili.

> DCE Digitalized Control of machine's end points

Digitalized control of machine's end points system projected and implemented by LAZZATI.
Von LAZZATI entwickeltes und erstelltes digitales Steuersystem für fernliegende Maschinenpunkte.
Sistema di controllo digitale dei punti remoti della macchina progettato e sviluppato da LAZZATI.



Rapid fault diagnosis of mechanical problems; prompt and reliable localization of necessary spare parts; checking the sequences of the machine motions; assistance for operation of the machine.

Schnelle Fehlerdiagnostik und Problembhebung; maximale Maschinenverfügbarkeit; sofortige Ersatzteilbestimmung; minimale Servicekosten.

Immediata diagnosi e risoluzione dei problemi; massima disponibilità della macchina; immediata ed affidabile individuazione dei pezzi di ricambio; minimi costi di assistenza.

>LRD LAZZATI Remote Diagnosis

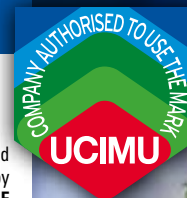

Tool Overload Control.
Werkzeugüberwachung der Leistungsaufnahme.
Controllo Adattativo Tecnologico.

>LFC LAZZATI Feed Control

>LA Coolant System

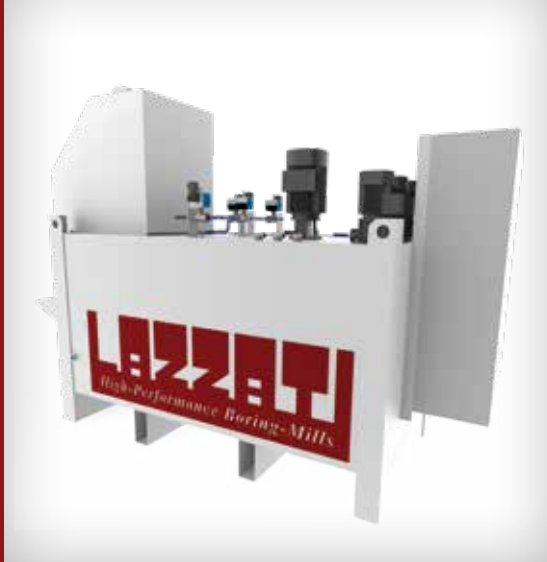

COOLANT SYSTEM:

- The LA System is composed by a **separate tank - unit of 1.000Lt. for decanting - filtration of coolant**, which is recovered by the foundation. This system allows a longer lifetime and efficiency of the entire coolant system of the machine.
- A **Grundfos High Pressure Pump, controlled by CNC**, is dedicated to the delivery of **coolant inside and outside the spindle**. The pump has a capacity of **20Lt/1'** at a maximum pressure of **35bar**.
- All coolant is filtered before collecting in the tank through a **filter cartridge of 60µ**.
- The recovery and filtration system of the coolant allows considerable cost savings, it facilitates its disposal and it is indispensable for the use of drilled tools.
- A series of **pressure and flow digital switches** constantly monitor the proper functioning of the coolant system.
- There is an **electronic level with a display on the CNC** to control the liquid level in the tank.
- The coolant unit is standardly equipped with a **immersion type refrigeration unit** for the coolant and oil temperature control.

AVAILABLE OPTIONS: LA KP - Paper Filter 40 µ • LA 2.000 - Coolant Tank - 2.000Lt • LA 50 - High Pressure Pump controlled by CNC - 50Bar - 25lt/1'.

KÜHLMITTELANLAGE:

- Es ist ein **separates Kühlmittelaggregat mit 1.000 Liter Behälter zum Dekantieren bzw. zum Filtern der Kühflüssigkeit vorhanden**, wobei diese in einem Behälter im Fundament gesammelt wird. Dieses System erlaubt eine beträchtliche Ersparnis, da eine bessere Lebensdauer und Leistung des Kühlsystems in der Maschine sichergestellt ist.
- Eine **Hochdruckpumpe vom Fabrikat Grundfos wird von der CNC angesteuert** und liefert das Kühlmittel sowohl für Innen als auch für Außen zur Spindel. Die Pumpe hat eine Förderleistung von **20 l/min** bei einem Höchstdruck von **35 bar**.
- Das gesamte Kühlmittel wird vor dem Sammeln im Behälter durch **einen Kartuschenfilter mit 60µ Feinheit gefiltert**.
- Die Anlage zur Rückgewinnung und Filterung des Kühlmittels ermöglicht eine beträchtliche Kosteneinsparung bei der Flüssigkeit und erleichtert die Entsorgung derselben. Sie ist bei Werkzeugen mit Kühlmittelbohrungen unerlässlich.
- Ein Satz an **digitalen Druckwächtern und Durchflusswächtern** überwacht laufend das einwandfreie Funktionieren des Systems.
- Es ist eine **elektronische Füllstandsmessung mit Anzeige an der CNC zwecks Überwachung des Füllstands im Behälter vorhanden**.
- Der Aggregatsbehälter ist serienmäßig mit einem Kühlaggregat in der Eintauchversion zur laufenden Temperaturüberwachung sowohl des Kühlmittels als auch des Öls ausgestattet.

OPTIONEN: LA KP - Papierfilter-Aggregat mit Feinheit von 40 µ • LA 2.000 - Behälter mit Fassungsvermögen von 2.000 Litern • LA 50 - Hochdruckpumpe über CNC angesteuert für 50 bar und 25 Liter/min.

IMPIANTO REFRIGERANTE:

- È presente una **vasca - centralina separata da 1.000Lt. per la decantazione - filtrazione del liquido refrigerante** che viene recuperato dalla fondazione. Questo sistema permette notevoli risparmi perché consente una maggiore durata ed efficienza dell'impianto di refrigerazione della macchina.
- Una **Pompa Grundfos ad Alta Pressione gestita dal CNC** è dedicata alla mandata del **Refrigerante Interno ed Esterno al Mandrino**. La Pompa ha una portata di **20Lt/1'** ad una pressione massima di **35Bar**.
- Tutto il refrigerante viene filtrato prima della raccolta nella vasca attraverso un **filtro a cartuccia da 60µ**.
- L'impianto di recupero e filtrazione del liquido refrigerante permette notevoli risparmi sul costo del liquido e facilita lo smaltimento dello stesso, ed è indispensabile per l'uso di utensili forati.
- Una serie di **presso-stati e flusso-stati digitali** controllano costantemente il buon funzionamento del sistema.
- È presente un **livello elettronico con visualizzazione sul CNC** per il controllo del livello del liquido nella vasca.
- La vasca - centralina è dotata di serie di una **centrale frigorifera del tipo a immersione** per il costante controllo della temperatura sia del liquido refrigerante che dell'olio.

OPZIONI: LA KP - Impianto di filtrazione a Carta Knoll KF 150 40 µ • LA 2.000 - Vasca - Centralina 2.000Lt • LA 50 - Pompa Grundfos ad Alta Pressione gestita dal CNC 50Bar - 25Lt/1'.



>G MT Guards H 2.500

Perimeter protections H=2.500mm. to protect the working area.

Maschinenumhausung für Verkleidung H=2.500mm.

Protezioni perimetrali H=2.500mm. a protezione dell'area di lavoro.

> TCS Thermal Control System

Control and thermo stabilization in process of the machines temperature by means of coolant, at controlled temperature.

Überwachungs- und Thermostabilisiersystem der Maschinentemperaturen durch temperaturgeregeltes Kühlmittel.

Sistema di controllo e termostabilizzazione delle temperature della macchina mediante liquido refrigerante a temperatura controllata.

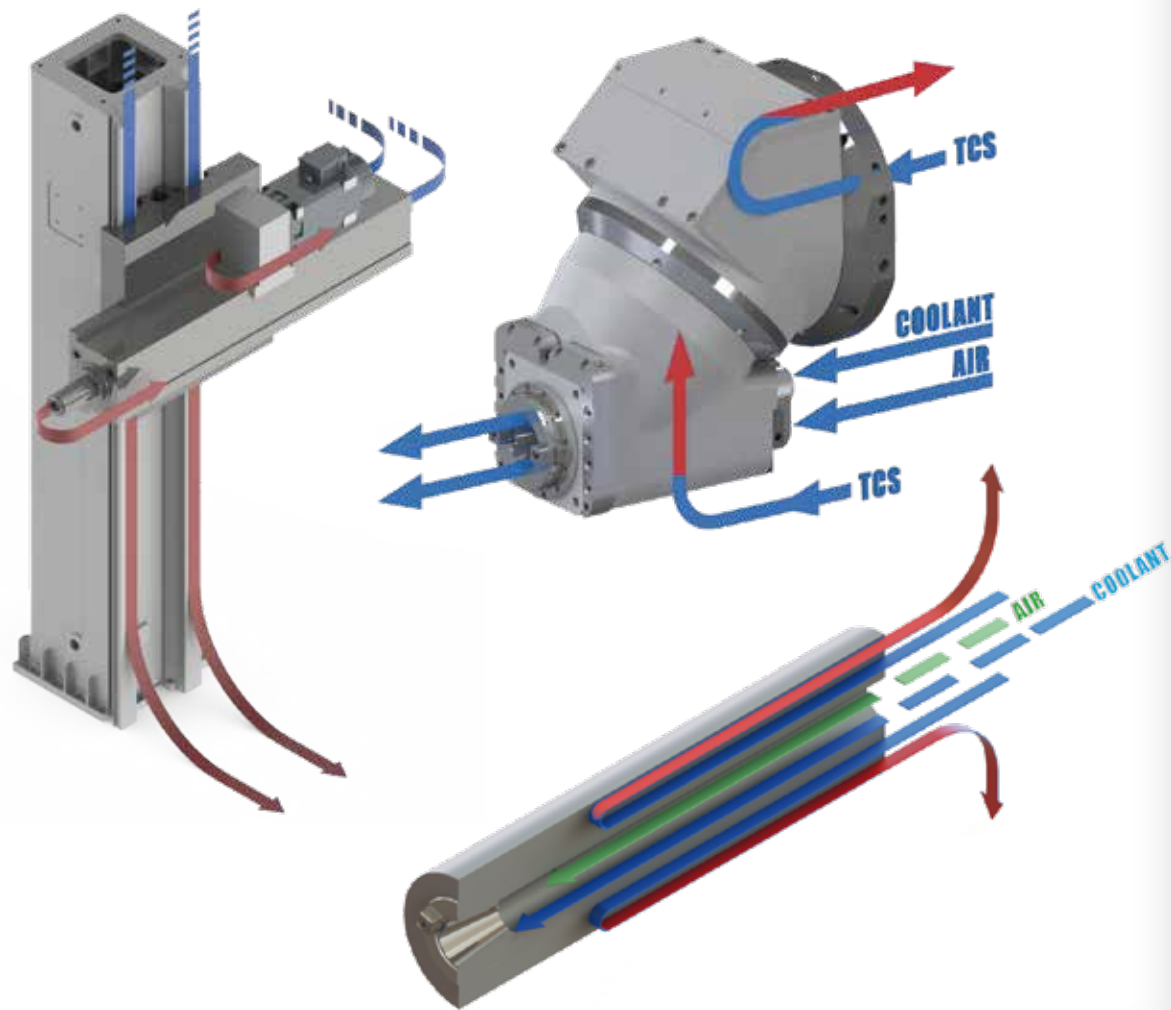

LAZZATI spindle line accuracy <

1. All the measuring must be in a room without any exposal to the Sun.
2. All the measuring must be at constant temperature.

1. Alle Messungen werden in einem Raum ohne Sonneneinstrahlung durchgeführt
2. Alle Messungen werden bei konstanter Temperatur durchgeführt von.

1. Tutte le misurazioni devono essere eseguite in ambiente senza esposizione a raggi solari.
2. Tutte le misurazioni devono essere eseguite a temperature costante.

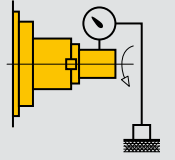
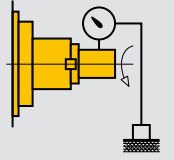
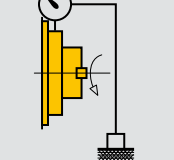
SPINDLE LINE PRECISION	GENAUIGKEIT DER SPINDELGRUPPE	PRECISIONE LINEA MANDRINO
		
DIN 8620-1 LAZZATI 0,03 mm 0,01 mm	0,03 mm 0,01 mm	0,015 mm 0,01 mm

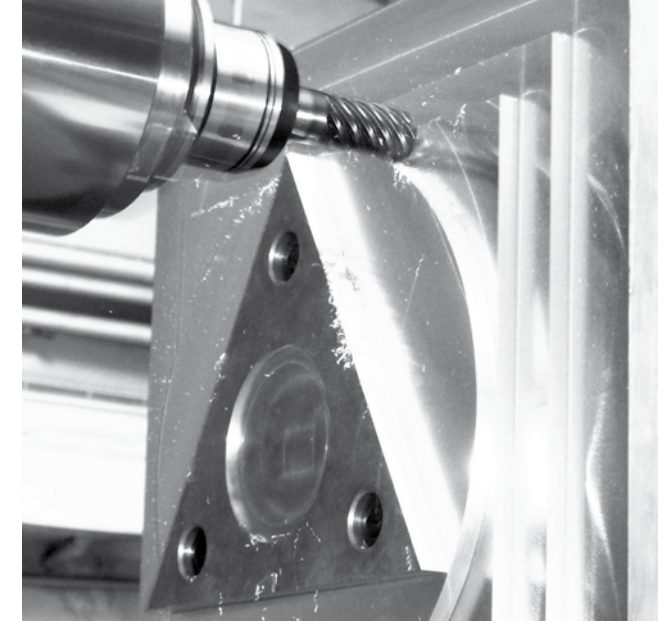

Working accuracy <

PRECISION ON DIAMETER
(Internal Boring)
Up to 125mm.

Over 125mm.

GENAUIGKEIT AM DURCHMESSER
(Innenausboren)
Durchmesser bis 125 mm.

Durchmesser über 125 mm.

PRECISIONE SUL DIAMETRO
(Alesatura Interna)
Fino a 125mm.

Oltre a 125mm.

IT7

IT6

DEVIATION FROM TRUE CIRCLE
(internal boring)
Diameter 160mm.

RUNDHEIT
(innenausboren)
Durchmesser 160 mm.

DEVIAZIONE SUL CERCHIO
(alesatura interna)
Diametro 160mm.

$\mu\text{m} \pm 5$

DEVIATION FROM TRUE CIRCLE
(external milling, circular)
Diameter up to 300mm.
Coaxiality of Circles

RUNDHEIT
(ausenfräsen, zirkularinterpolation)
Durchmesser bis 300 mm.
Konzentrität der Kreise

DEVIAZIONE SUL CERCHIO
(fresatura circolare esterna)
Diametro fino a 300mm.
Co-Assialità dei Cerchi

$\mu\text{m} \pm 8$

$\mu\text{m} \pm 10$

POSITIONING ACCURACY
(According to VDI/DGQ 3441 standards)

Axis X - Y - Z on 1.000mm

Positioning Uncertainty P

Mean Repeatability Ps-med

Mean Positioning Error Pa-med

Mean Reversal Error U max

Axis B (with Heidenhain ROD 880)

Positioning Uncertainty P

90° Positioning

POSITIONIERGENAUIGKEITEN
(Nach VDI/DGQ 3441)

Bezugsweg der Achsen X/Y/Z bei 1.000mm.

Positionier-Unsicherheit P

Mittlere Wiederholbarkeit Ps med

Mittlere Positionierung Pa med

Mittleres Umkehrspiel U med

Axis B (mit Heidenhain ROD 880)

Positionier-Unsicherheit P

Positionier 90°

PRECISIONE DI POSIZIONAMENTO
(Secondo la norma VDI/DGQ 3441)

Assi X - Y - Z su 1.000mm.

Incertezza di Posizionamento P

Ripetibilità Media Ps-med

Errore di Posizionamento Medio Pa-med

Errore di Inversione Medio U

Asse B (con Heidenhain ROD 880)

Incertezza di Posizionamento P

Posizionamento a 90°

$\mu\text{m} \pm 5$

$\mu\text{m} \pm 4$

$\mu\text{m} \pm 3$

$\mu\text{m} \pm 1,5$

Sec +/- 2"

Sec 2"

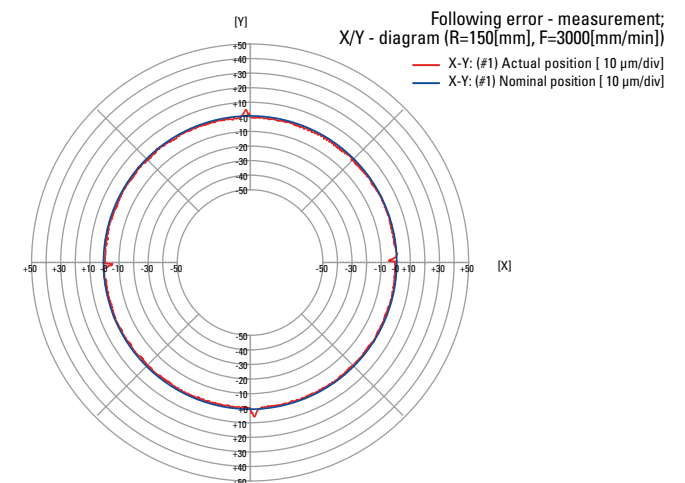



The machine is standardly equipped with CNC Heidenhain. On request, CNC Siemens, Fanuc or Fagor are also available.

Standardmäßig wird die Maschine mit einer Heidenhain CNC Steuerung ausgerüstet, alternativ können die Maschinen auch mit CNC Steuerungen von Siemens, Fagor oder Fanuc ausgerüstet werden.

La macchina è equipaggiata di serie con CNC Heidenhain. In opzione, su richiesta del Cliente, sono disponibili i CNC Siemens, Fanuc e Fagor.

LAZZATI Accessories >

Heads
Kopfes
Teste >

A UA 360



A UA 360.000



A VA ISO 50



A VA ISO40



A UM

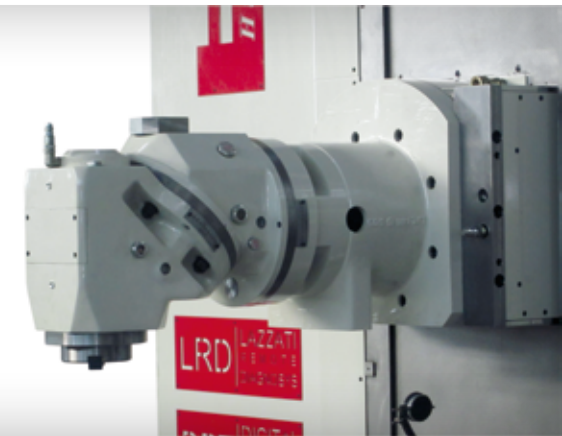

A SC/L

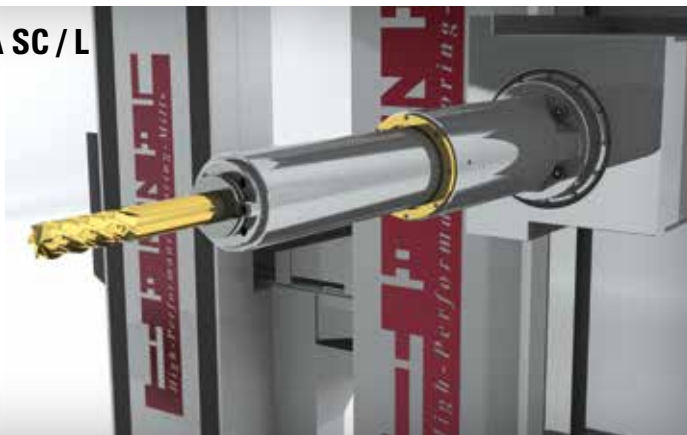

A TE



A FH - D'ANDREA

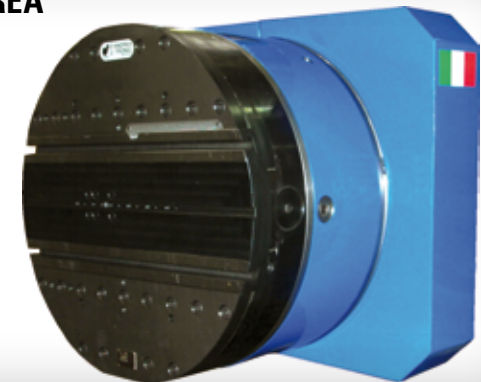

> TW-K Pick up Station



Automatic Accessories Change.
Automatik Zubehörwechsler.
Sistema di Cambio Automatico Accessori.

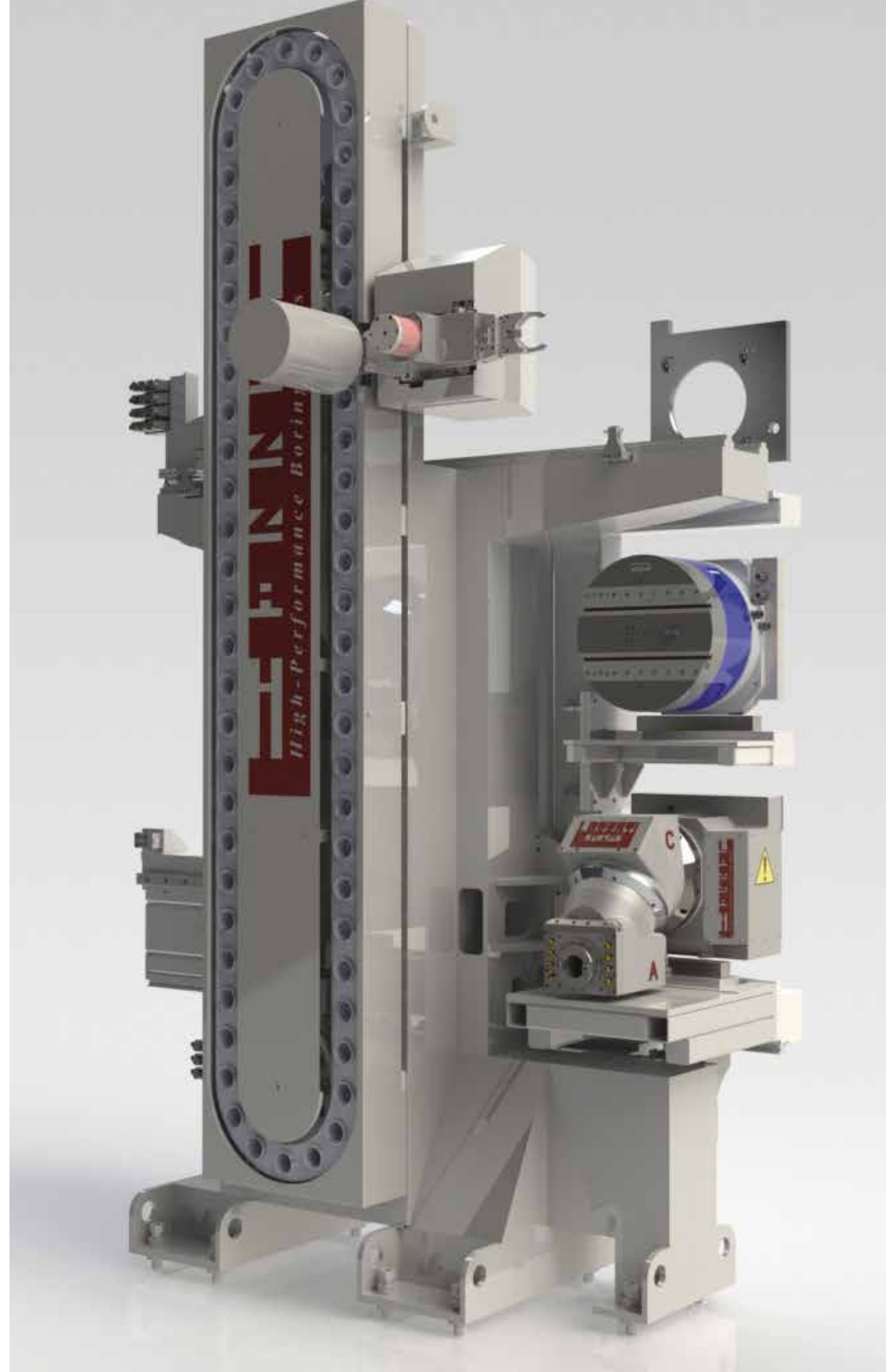

>TW

Automatic On Ground Tool Changer Auf-Flur Automatik WZ - Wechsler Cambio Utensile Automatico a Terra

Tool Pockets
Chain Pitch
Max. Tool Weight
Max. Ø consecutive tool
Max. Ø not consecutive tool
Max. Tool Length
Tilting Moment

Werkzeugplätze
Abstand WZ Tasche zu WZ Tasche
Max. Gewicht je Werkzeug
Max. Ø Werkzeugdurchmesser
Max. Ø WZ bei einem freien Platz
Werkzeuglänge max
Kippmoment

Posti utensile
Passo catena
Peso Max. utensile
Max. Ø utensile consecutivo
Max. Ø utensile non consecutivo
Lunghezza massima utensile
Momento ribaltante

60-120
130-140-160 mm.
20-25-35-50 Kg.
125-135-150 mm.
215-315
600 mm.
40-60-80 Nm



Semiautomatic system of Table Change

>H-Ø

This new system allows the replacement of the table carrying the pieces in semiautomatic way and in very short times, practically eliminating the set-up times. The system is composed by a main table with four hydraulic clampings, by precise systems of centring and eventually by two or more over-tables that, once clamped, become the new bench of job.

Dieses neue System erlaubt das Wechseln des Werkstücktisches auf halbautomatische Betriebsart und dabei mit geringstem Zeitaufwand, wodurch praktisch die Rüstzeiten eliminiert werden. Das System besteht aus einem Haupttisch mit vier hydraulischen Klemmungen, aus genauen Zentriervorrichtungen und eventuell aus zwei oder mehreren Aufsatztischen, die nach der Klemmung wiederum zum neuen Werkstücktisch werden.

Questo nuovo sistema permette la sostituzione della tavola porta pezzo in modo semiautomatico ed in tempi ridottissimi, praticamente eliminando i tempi di set-up. Il sistema è composto da una tavola principale con quattro bloccaggi idraulici, precisi sistemi di centraggio ed eventualmente da due o più sopra tavole che, una volta bloccate, divengono il nuovo banco di lavoro.

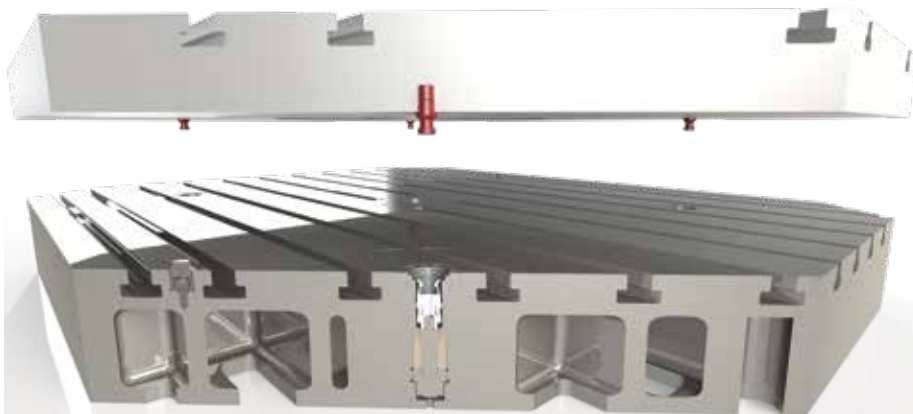

> Productivity

0 RT3D

Management of Heads in the Space 3D
3D Fräsen Automatikfräsköpfe
Sistema di gestione automatica della testa nello spazio

0 SU

Tool touch-probe system
Werkzeugvermessung
Sistema a sonda per utensili

0 SP

Workpiece touch-probe system
Werkstückvermessung
Sistema a sonda per pezzo

0 CM

Collision Monitoring System
Monitoring-System Kollision
Sistema di monitoraggio collisione



> Linea T-TYPE

*

HEADSTOCK	BOHR SPINDEL	TESTA	
Ø Spindle	Spindeldurchmesser	Ø Mandrino	mm
Spindle Taper	Aufnahme	Attacco Cono	ISO
Max. Rotation Speed	Max. Drehzahlen	Max. Velocità	RPM
Motor Max Power	Max. Motor -Leistung	Potenza Max. Motore	kW
Motor Max Torque	Max. Drehmoment Spindelmotor	Coppia Max. Motore Mandrino	Nm
RAM Section	Sektion des RAM	Sezione RAM	mm
TRAVELS	VERFAHRWEGE	CORSE	
Long. Ram - V	Längsweg des Ram - V	Long. Ram - V	mm
Spindle - W	Spindel - W	Mandrino - W	mm
Vertical Head - Y	Vertikalweg - Y	Verticale Testa - Y	mm
Long. Column - Z	Längsweg Ständers - Z	Long. Montante - Z	mm
ROTARY TABLES	DREHTISCH	TAVOLA GIREVOLE	
Version	Version	Versione	
Cross Table - X	Querweg Tisches - X	Trasversale Tavola - X	mm
Min. Surface - B	Min. Tischfläche - B	Superficie Min. - B	mm
Max. Surface - B	Max. Tischfläche - B	Superficie Max. - B	mm
Max Centered Load	Max. Belastung	Carico Max. Centrato	Ton.
Rapid Feeds	Eilgang	Rapidi	mm/1'

		BORING			MILLING			
		HB 130T	HB 150T	HB 160T	HB 2TF			
		130 - 150	150	150 - 160 - 180	A UA 360 (360.000)			
		50 - Big Plus	50 - Big Plus	50 - Big Plus	50 - Big Plus			
		4.000	4.000	4.000	6.000			
		75	75	80	75			
		1.200 - 3.250	3.250	4.000	1.000			
		515 x 510	515 x 510	515 x 510	500 x 400			
		Fix	Fix	Fix	Fix			
		900	900	1.100 - 1.300	-			
		2.000 ÷ 3.000	2.000 ÷ 3.500	2.000 ÷ 3.500	2.100 ÷ 3.100			
		1.500 ÷ 3.000	1.500 ÷ 3.000	1.500 ÷ 3.000	1.500 ÷ 3.000			
		TRT-15	TRT-25	TRT-40	TRT-40	TRT-60	TRT-15	TRT-25
		2.000 ÷ 4.000	2.500 ÷ 5.000	3.000 ÷ 6.000	3.000 ÷ 6.000	3.000 ÷ 7.000	2.000 ÷ 4.000	2.000 ÷ 5.000
		1.600 x 2.000	1.600 x 2.000	1.650 x 2.000	1.650 x 2.000	2.500 x 2.500	1.600 x 2.000	1.600 x 2.000
		1.800 x 2.400	1.800 x 2.400	2.000 x 3.000	2.500 x 3.000	3.000 x 3.500	1.800 x 2.400	1.800 x 2.400
		15	25	40	40	60	15	25
		18.000	15.000	15.000	15.000	12.000	18.000	15.000

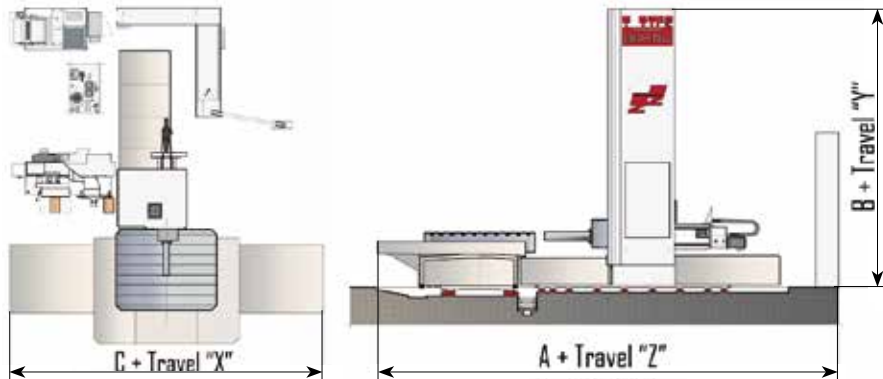

* > Approx Overall dimensions (mm.)

MODEL	HB 130T		HB 150T	HB 160T		HB 2TF	
TRT	TRT-15	TRT-25	TRT-40	TRT-40	TRT-60	TRT-15	TRT-25
A	5.500	5.550	6.100	6.400	7.100	4.500	4.550
B	2.850	2.850	2.850	2.850	2.850	2.850	2.850
C	3.270	3.650	3.800	3.800	4.600	3.270	3.650

* The specifications and information above-mentioned may be changed without prior written notice.
 * For more details please contact LAZZATI.

RAM-MILLING

RAM-BORING

HB 2T

HB 5T

HB 150MT

HB 160MT

A UA 360 (360.000)

A UA 360 (360.000)

130 - 150 - 160

150 - 160 - 180

50 - Big Plus

50 - Big Plus

50 - Big Plus

50 - Big Plus

5.000

5.000

4.000

4.000

75

75

75

80

1.100 - 2.000

1.100 - 2.000

3.250

4.000

480 x 390

480 x 390

560 x 515

560 x 515

1.300

1.300 - 1.600

700 - 1.000

700 - 1.000

-

-

800 - 1.000

1.000

2.000 ÷ 3.000

2.000 ÷ 3.500

2.000 ÷ 3.000

2.000 ÷ 4.000

1.500 ÷ 3.000

1.500 ÷ 3.000

1.500 ÷ 3.000

1.500 ÷ 3.000

TRT-15

TRT-25

TRT-40

TRT-15

TRT-25

TRT-40

TRT-60

2.000 ÷ 4.000

2.000 ÷ 5.000

3.000 ÷ 6.000

2.000 ÷ 4.000

2.000 ÷ 5.000

3.000 ÷ 6.000

3.000 ÷ 7.000

1.600 x 2.000

1.600 x 2.000

1.650 x 2.000

1.600 x 2.000

1.600 x 2.000

1.650 x 2.000

2.500 x 2.500

1.800 x 2.400

1.800 x 2.400

2.500 x 3.000

1.800 x 2.400

1.800 x 2.400

2.500 x 3.000

3.000 x 3.500

15

25

40

15

25

40

60

18.000

15.000

15.000

18.000

15.000

15.000

12.000

HB 2T

HB 5T

HB 150MT

HB 160MT

TRT-15

TRT-25

TRT-40

TRT-15

TRT-25

TRT-40

TRT-60

6.100

6.200

6.400

7.000

7.100

7.300

8.000

2.850

2.850

2.850

2.850

2.850

2.850

2.850

3.270

3.650

3.800

3.270

3.650

3.800

4.600



BORING



MILLING



RAM-MILLING

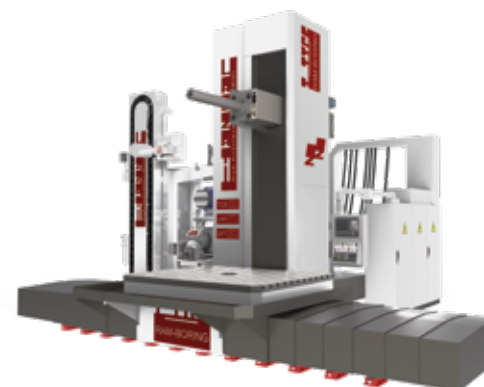

RAM-BORING

> **T-TYPE**
CONTINUOUS
HEAVY
PRECISION
PASSION



> LAZZATI Linea FLOOR-TYPE

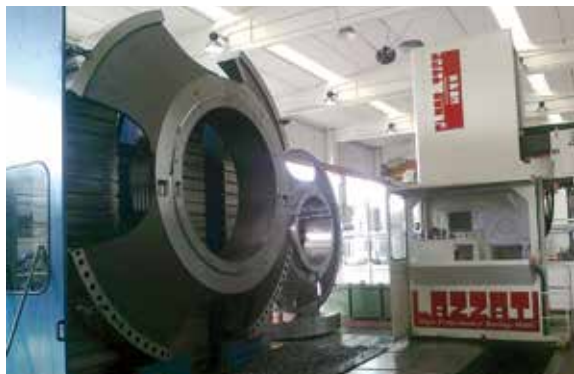



LAZZATI
High-Performance Boring-Mills®



LAZZATI S.p.A.
Via Rugareto, 7 - 20027 Rescaldina (MI) ITALY
Tel. +39.0331.465.200 - Fax +39.0331.464.151
lazzati@lazzati.eu - www.lazzati.eu

MADE IN ITALY

